

1 Year Limited Warranty

Please take time to read about the protection we offer you.

All our products come with a guarantee designed to protect you as our valued customer. ZEMPIRE® Camping Equipment will repair or replace this product, at their discretion, should it fail due to faulty materials or manufacture for a period of 1 year from the date of purchase.

The Guarantee is subject to the following conditions:

1. The Guarantee only applies to an original purchaser who purchased this product in an unopened condition from an approved retail outlet.
2. The Guarantee does not apply if the product has been used for anything other than reasonable personal use. Commercial use (e.g. rental) or continuous use are expressly excluded.
3. Damage due to normal wear and tear, accident, acts of God, negligence (other than by ZEMPIRE® Camping Equipment), failure by the purchaser to ensure instructions for setting up and care are observed, deterioration due to abnormal exposure to ultraviolet light, insect or mildew attack, or any other cause reasonably beyond the control of ZEMPIRE® Camping Equipment are not covered.
4. If redress is sought under the terms of this Guarantee, then the product must be returned by the purchaser to the outlet from where it was purchased within the Guarantee period, in a clean, dry state and with proof of purchase.
5. All transport costs and any other indirect costs are excluded from the Guarantee.
6. ZEMPIRE® Camping Equipment reserves the right to make a reasonable charge for repairs which it determines are not within the scope of the Guarantee.
7. The Guarantee does not limit, modify or exclude any rights under any law if doing so would contravene that law or make any part of this Guarantee invalid. However, ZEMPIRE® Camping Equipment:
 - a) excludes (to the extent permitted by applicable law) all conditions and warranties that might otherwise be implied; and
 - b) limits its liability for breach of any such condition or Guarantee that it cannot exclude together with its liability under the Guarantee, to repairing or replacing the Goods or paying the cost of having the Goods repaired or replaced (at ZEMPIRE® Camping Equipment's option).

Australia Only

Our goods come with guarantees that cannot be excluded under the Australian Consumer Law. You are entitled to a replacement or refund for a major failure and compensation for any other reasonably foreseeable loss or damage. You are also entitled to have the goods repaired or replaced if the goods fail to be of acceptable quality and the failure does not amount to a major failure.

USA Only

Some states do not allow the exclusion or limitation of incidental or consequential damages, so the above limitation or exclusion may not apply to you. This warranty gives you specific legal rights, and you may also have other rights which vary from State to State.

Europe Only

The consumer has legal rights under applicable national legislation governing the sale of consumer goods and those rights are not affected by the guarantee.

International Distributors:

New Zealand & Australia

ZEMPIRE® Camping Equipment
6 Karewa Place, Pukete,
Hamilton, 3200, New Zealand
Ph: +64 7 848 1610

United Kingdom, Belgium, Netherlands & Luxembourg

Outdoor & Sports Company Ltd.
Redfern House, Dawson Street
Hyde, Cheshire, SK14 1RD, UK
Ph: +44 161 366 5020

North America

Outdoor & Sports Company Inc.
610 Alden Road Unit 101
Markham, ON, L3R 9Z1, Canada
Ph: +1 905 940 9511

Germany, Austria, & Switzerland

Sport-tech
Goldbeckstrasse 6
69493 Hirschberg, Germany
Ph: +49 6201 8439710

South Korea

Coldspin Corporation
20 Gurodong-ro 15-gil
Guro-gu, Seoul, South Korea
Ph: +82 2 3397 7711

INS-0181309-0000

Zempire®  **SUPERCELL**
CAMPING EQUIPMENT PUMP

INSTRUCTIONS



For a detailed description of all the features and specifications of this product please visit our website.

WWW.ZEMPIRE.CO.NZ

Tested in New Zealand. Made with care in China.

Zempire®
CAMPING EQUIPMENT 

INSTRUCTIONS

INFLATION

1. Connect vehicle power adapter plug to a DC 12V power source.
2. Connect one end of the hose to the INFLATE port of the pump and the opposite end of the hose firmly into the open valve of the product you wish to inflate.
3. Turn the pressure switch to the desired pressure setting, then press the ON button to begin inflation.
4. Once the pressure reaches the desired pressure setting the pump will stop automatically.
5. Detach the hose from the valve and tightly close the valve cap.

NOTE: The pump operates in 2 stages and will produce a distinct sound as your inflatable reaches higher pressures. This is normal and does not indicate a flaw or damage to your pump.

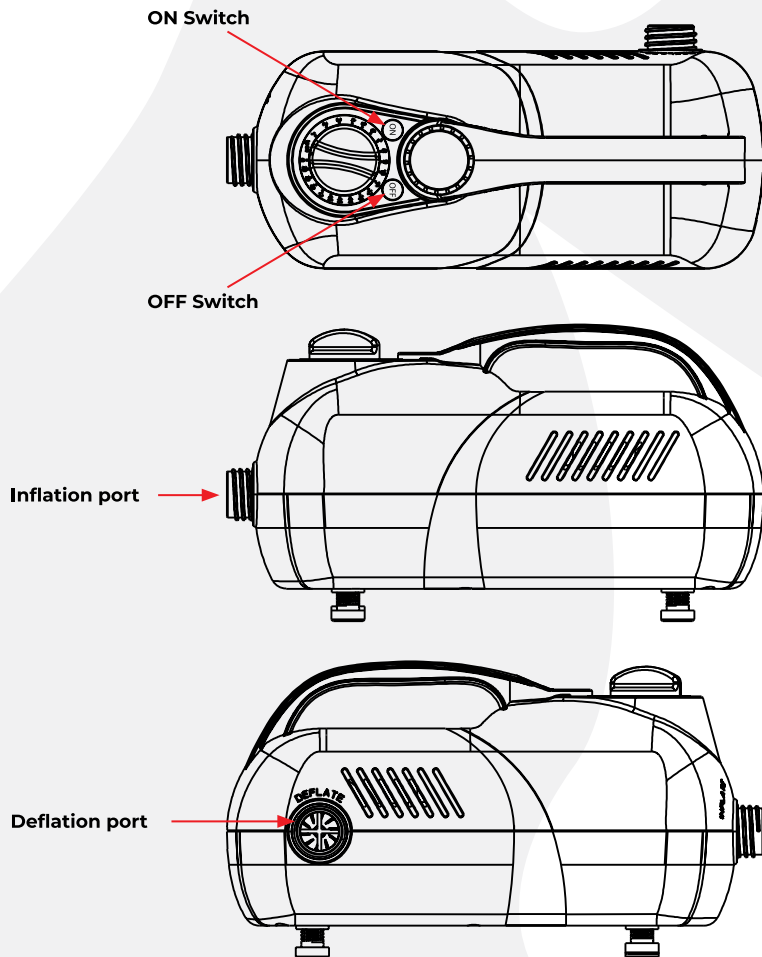

DEFLATION

NOTE: The deflation setting is not intended for use with inflatable tents. Please refer to your tent's instructions for deflation.

1. Connect one end of the hose to the DEFLATE port of the pump and the opposite end of the hose firmly into the open valve of the product you wish to deflate.
2. Turn the pressure switch to the 'I' position and then press the ON button to begin deflation.
3. Once deflation is complete, press the OFF button and turn the pressure switch to the 'O' position.
NOTE: You must manually press the OFF button to stop deflation.
4. Detach the hose from the valve and tightly close the valve cap.



Attention!

IMPORTANT

- Power supply must be **12 Volt DC**.
- This pump is designed to inflate items such as **air tents, SUP boards and inflatable boats**. It is not designed for continuous use.
- **DO NOT** operate the air pump for **more than 20 minutes** at a time.
- Keep the air pump out of reach of children.
- **DO NOT** obstruct the inflation/deflation ports and keep them ventilated at all times.
- To disconnect, turn all controls to the OFF position, then remove plug from outlet.
- Return the pump, DC adapter and nozzles to package when not in use.
- When the **pump is not in use**, it is recommended to always turn the pressure switch knob to number **'0'** position.

WARNING

- Carefully follow the instructions on the inflatable item when inflating. Never exceed the recommended pressure, otherwise, serious injury might be caused by the item bursting.
- To reduce the risk of electric shock, do not expose to rain or use around water.
- Always store in a cool dry area, away from heat and moisture.
- Never attempt to disassemble or repair. If the power cord is damaged, it must be replaced by the manufacturer, its service agent or similarly qualified person in order to avoid hazard.
- This product must not be disposed of with domestic waste. Check your local regulations for proper disposal instructions.
- This air pump is not intended for use by young children or infirm persons unless they have been adequately supervised to ensure that they can use the air pump safely.
- Do not attempt to put any objects into the inflation or deflation connector at any time. Keep the inflation/deflation ports clear of sand, small rocks, etc, when using the pump.
- Never look inside or point the inflation/deflation port towards your eyes when the pump is in use.
- Use this unit only for its intended use as described in these instructions. Do not use attachments not recommended by the manufacturer.
- Never leave the pump unattended while in use. Always unplug the pump when not in use.
- Keep the cord away from heated surfaces.
- Do not tamper with the HOSE near the INFLATE port while operating.